

March 2017 NEWSLETTER

April Meeting - 6:45 PM - Tuesday , April 4, 2017

Upcoming Work Sessions at the Depot - "Revised"

Saturday April 1, 8 am - 3 pm
Sunday April 2, 2017, 8 am - 3 pm

2017 DUES Another Year and dues are due. \$5.00. No increase ever. Same as 1974. You can buy 2 gallons of gas for the fun of providing fun and cheer to thousands of folks. Bring your dues to a meeting, a work session, or mail dues to Ellen Lindvig at 2034 Glenwood Ave, Eau Claire, WI 54703

No 16 Boiler Project. Jeff Lund, New Ulm, MN, continues work on the boiler. Sunday, March 26th, drove over to check on the progress. Several items relating to design items we wanted were discussed. Rob and I believe we are in agreement with the items we want. We will schedule another review in April. The project looks to be completed by May 1st.

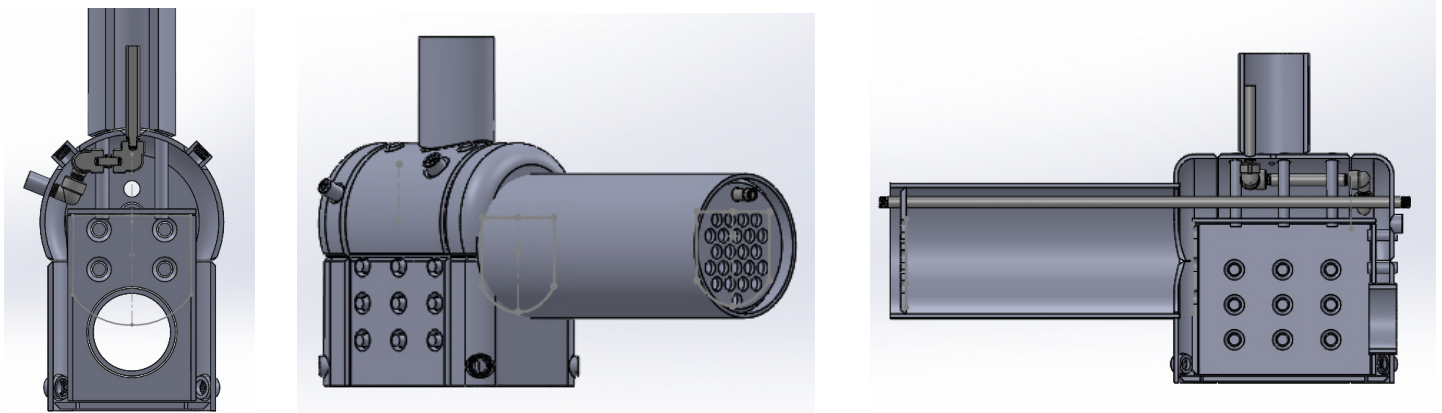

No 16 Boiler Schematic Drawing. Jeff Lund created these drawings for the new boiler. Left is the backhead with the fire door hole. Center is a 3/4 view showing the wrapper sheet with the steam dome and the boiler tube with the front tube sheet. Right is the section view. Forklift to right - boiler tube, firebox and steam dome, and backhead with fire door hole.

CHIPPEWA VALLEY RAILROAD ASSOCIATION



Backhead, Wrapper Sheet and Throat Sheet. The backhead, wrapper and throat sheets are welded together. The components are upside down in Jeff Lund's mill to true seam where lower sheets will be attached. Then the exterior of the firebox will be completed. The boiler tube or course will be attached.



Firebox. The firebox is shown here. It is upside down also. Currently it is tack welded together. The 9 holes are for the stay bolts that connect the firebox to the side of the wrapper sheet. The 2 holes on the end will receive the horizontal stays.

**CHIPPEWA VALLEY RAILROAD
ASSOCIATION**

ELECTRICAL UPGRADE WEEK END WORK SESSION

Saturday April 1, 2017, 8 am - 3 pm

Sunday April 2, 2017, 8 am - 3 pm (if needed)

Mike Kuhn is heading up the electrical upgrade beginning this weekend. The upgrade will help us bring our electrical service up to new code standards and replace the electrical main with a box for which we can by breakers. We will also provide a new line to the roundhouse and to the tower.

The new 200 amp panel that will be installed in the south-east corner of the depot be an upgrade from the existing 100 amp panel. The new panel will serve the new lathe and the mill with the correct amperage.

This weekend is the first phase. We will trench in the conduit for the new electrical service that will run form Excel's pole near the tower to the south east corner of the depot. We will also trench in conduit to the north end of the depot for the run to the roundhouse.

We are renting a trencher and Janson Miller will be bringing a small digger.

Tammy Kuhn is providing lunch. Chuck Lindvig has sent a notice to everyone. If you want lunch, let Chuck know by responding to his notice.

Please participate. Any work we do will reduce the overall cost provided by TJ Electric. Most of the work we can do is labor like the trenching and installing the conduit. Certain portions of the work requiring a licensed electrician will be performed by TJ.

CHIPPEWA VALLEY RAILROAD

Agenda - April 4, 2017, 6:45 PM at Chippewa Valley Museum, Eau Claire, WI

Agenda Approval

Minutes of the March 7 meeting . Review and Approval.

Treasure's Report for Review and Approval

Updates...

- Diesel 8101 complete. Requires final inspection
- No. 19. Driving blocks and brake components will be installed in the spring.
- Recognition Day - Recognize various members and their efforts. Something for Memorial Day?
- Track extension. Chippewa Corrections. June time slot best for track work.
- Straighten and level track and ballast. Spring work
- Fund Raising discussed for No 16 boiler, track relocation, and tower completion. Discuss this meeting
- No. 16 Boiler replacement update. Bankhead and throat sheet arrived. Both attached to wrapper sheet. Fire box tacked together waiting new crown sheet.
- Semaphore mast. Dan Perkins has two leads for relocating the masts.
- Road crossing mostly complete. Need some tie leveling at east end.
- Complete the painting of the trolley stop. Almost complete.
- Lumber for roundhouse fascia purchased. Staining required. Dan Perkin staining the boards.
- Paint touchup.
- Gutters for the roundhouse and the back of the depot.
- Met with Lucas and his father. Discussed the the project. Appears to be moving ahead.
- G-16 coach truck inspection beginning. Discovered one wheel gage too wide. Checking springs now..

New Business...

- Recognition Day. Memorial Day?
- Approve bills.
- Electrical Service Upgrade. Report by Mike Kuhn.
- New Ulm Trip. Flue installation should be in progress. Schedule next visit.
- Chippewa Corrections crews. Week of June 5th. Discuss project priorities.
- Fund raising.
- Tower stairs - Contact persons.
- Boiler inspection date. Waiting for a date in May. Inspection is a visual this year.

- Carson Park event coordinations.
- Review insurance for fixed assets. Obtain estimates.
- Board review operating procedures.

Other Business

Next Meeting May 2, 2017, 6:45 PM, Chippewa Valley Museum.

Chippewa Valley Railroad Association

Monthly meeting March 3, 2017

6:45 p.m. Meeting called to order by President Dave Peterson

Members present: Dave Peterson President, Rob Brazeau Vice President, Ellen Lindvig Treasure, Chuck Lindvig, Marc Brown, Mick Henning, Andy Stanton, Paul Almquist, Jason Miller

- Approved agenda
Motion Marc Second Chuck Passed
- Secretary report reviewed. Minutes need to be amended to show Dave Peterson to pay half the repair bill for the Sulair compressor and that the club will defer the last car payment until July 2017.
Motion to approve minutes Chuck Second Andy Passed
- Treasure report was given.
Motion to approve Marc Second Paul Passed

Updates

- Dave reported that the tranny and truck have been installed in the diesel. Our recognition day for club members will be held on Memorial Day this year. The club will serve ice cream. The correction people will be at the park the first week in April and sometime in June.
- Dave gave an update on the new boiler for engine 16. The flange pieces are at the boiler shop, they came out of Canada.
- Dave, Chuck and Byron have looked at the Depot and noted repairs that need to be done.

New Business

- Dave reported that the boiler inspection will be due on engine 19 in May, engine 16 will come with a new inspection with the new boiler. The ride inspection is also due for this year. Motion to pay inspection fees Chuck Second Andy Passed
- Dave said he is planning a trip to New Ulm MN to check the progress on the new boiler, he will set something up for those interested in going along.
- Dave talked some about the fund-raising effort and the possibility of Charter Bank having naming rights for engine 16
- Dave discussed how the Tower stair's project was coming.
-

-
- Dave talked a little about starting work on the G16 coach, the work to be done on the second steaming bay and the repairing of the crane base and also the possibility of relocating the crane. Motion for lumber, concrete and rebar for these projects \$600.00 Chuck second Ellen Passed
- Dave said the eaves on the round house need to be replaced, Chuck said he will head this up.
- Dave reported that the Eau Claire Marathon will be held May 6 & 7. Could be difficult to get into the park.
- Dave talked a little about the value of our rolling stock and perhaps we are under insured. A hand out was given out, this will be something to look at in the future.
- Dave gave an update on the electrical work to be done. Mike will head this up. Motion to \$1500 to get this started Marc Second Chuck Passed
- Motion to adjourn Andy Second rob Passed at 8:00 p.m.

Submitted by Rob Brazeau